

Electric Powered Pallet Truck **BLUE GIANT**[®]

EPJ-45

Low cost electric pallet truck, ideal for crowded loading docks, work cells and congested aisles.

CAPACITY

- 4500 lb (2041 kg)

BATTERY

- 24-volt industrial battery/battery pack
- 224Ah AGM maintenance-free battery pack
- Minimum battery weight: 175 lb (79.4 kg)
- Ah capacity (min/max): 180/255
- Compartment dimensions (open): 26.4" x 9.1" (671 mm x 231 mm)
- Connector: SB-175 Gray—A-11

SPEED

- **EMPTY:** 0 - 3.66 mph (5.9 kph)
- **LOADED:** 0 - 3.5 mph (5.6 kph)

TIRES / WHEELS

- **DRIVE:** 9" x 3" (229 mm x 76 mm) polyurethane
- **LOAD:** 3.3" x 4.5" (84 mm x 114 mm) polyurethane
- Press-on polyurethane drive tire

HYDRAULICS

- Lift cylinder with hard chrome plated rods
- Pump unit including motor, gear pump, and solenoid are actuated using pressure compensated lowering valve

ELECTRICAL

- 24-volt ZAPI AC-0 travel control-inverter with matching drive motor provides high performance throughout the entire speed range
- Monarch drive motor
- Automatic rise and fused circuit protection
- Low battery lift interrupt
- Hour meter / battery discharge indicator combo

BRAKES

- Regenerative electromagnetic brake mounted on motor armature shaft, multiplying braking power through the transmission
- ZF GK10 transmission
- Brake is applied when control arm is in the vertical or horizontal position
- Neutral braking resists roll back on ramp

OPERATION / CONTROLS

- Ergonomic operator handle with travel, lift, and lower functions
- Angle grips allow easy operation with either hand
- Wrap-around guard
- Reversing switch
- Thumb control and horn



- Gas-assisted spring handle
- Creep speed function while steer handle is at 5° back-tilt from vertical

TRANSMISSION

- Vertically mounted drive motor direct mounted to gear housing
- Oil-bathed ZF GK10 hypoid bevel gear drivetrain
- State-of-the-art optimized gear technology provides minimal envelope circle, zero maintenance, and low noise level

BEARINGS

- **DRIVE WHEEL:** Tapered roller bearings sealed in oil bath
- **LOAD WHEELS:** Sealed ball bearings
- **FORK LINKAGE:** Self-lubricated heat-treated bushing

ACCESSIBILITY

- Removal of one piece power head cover exposes major components for inspection and maintenance
- Drive tire can be removed with one nut

STANDARD EQUIPMENT

- Steel wrap-around bumper

OPTIONAL EQUIPMENT

- Fork lengths: 36" or 60" (914 or 1524 mm)
- Fork widths: 18" or 21" (457 or 533 mm)
- 48" (1219 mm) tall load back rest
- Stability casters
- Cold conditioning
- 8.1" (206 mm) battery compartment

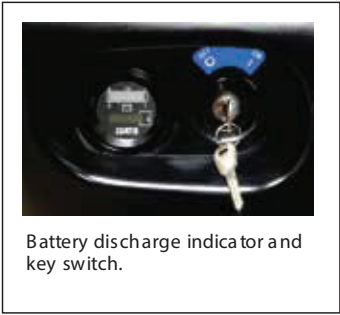

Battery discharge indicator and key switch.



Built-in automatic battery charger.



Ergonomic operator's handle

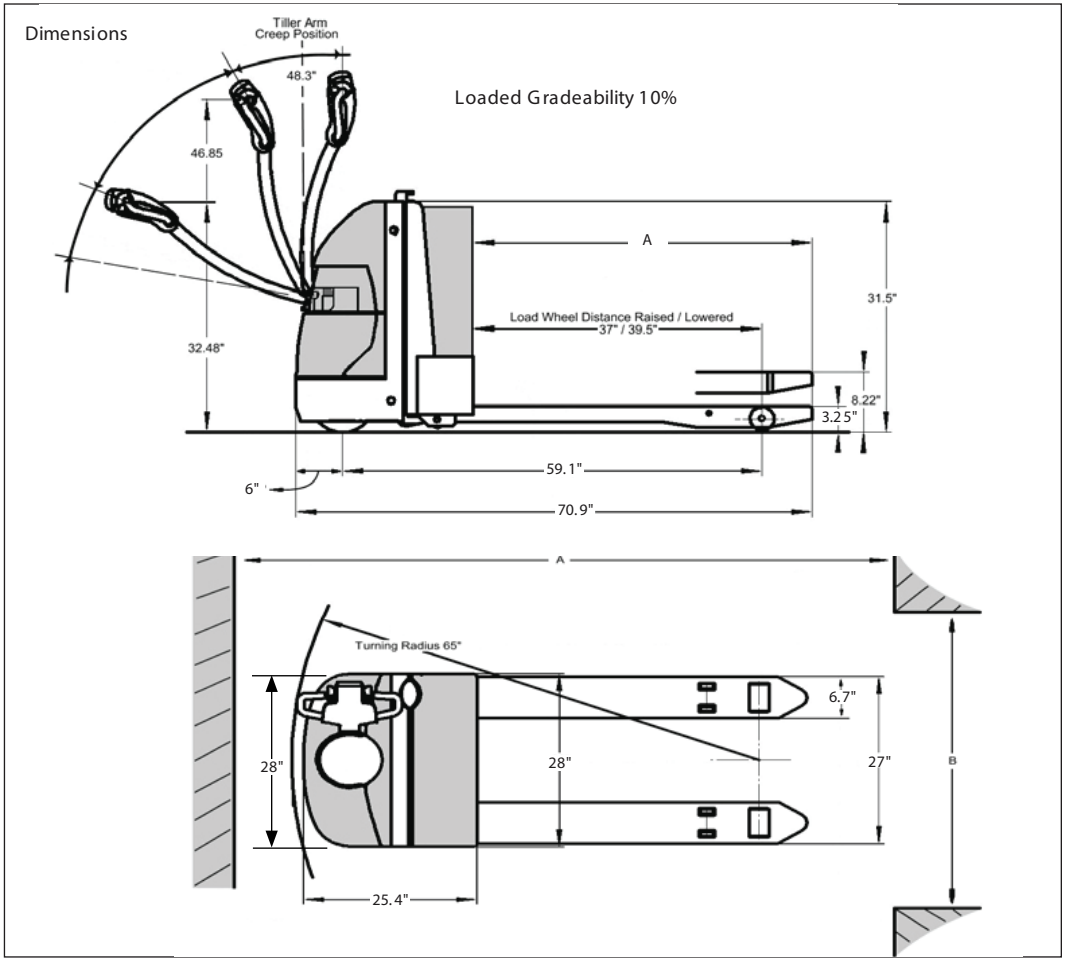

Gradeability	
Without Load	10%
With Load	6%
Travel - Variable	
Empty	0 to 3.6 mph
Loaded	0 to 3.5 mph

Model#	Forks	Actual Fork Width	Actual Fork Length	Turning Radius	Wheel - base	Overall Length	Inside Fork Width	Weight*	
								lb	kg
Fork Dimension: 27" (686mm) Wide		A	B	C	D	E	F		
EPJ-45	27" x 36" (686 x 914 mm)	27" (686 m m)	33.5" (851 m m)	56" (1422 m m)	50.1" (1273 m m)	61.9" (1572 m m)	13.4" (340 m m)	875	397
	27" x 48" (686 x 1219 mm)		45.5" (1156 m m)	68" (1727 m m)	59.1" (1501 m m)	70.9" (1800 m m)		885	401
	27" x 60" (686 x 1524 mm)		57.5" (1461 m m)	80" (2032 m m)	73.7" (1872 m m)	85.5" (2171 m m)		910	413
Fork Dimension: 21" (533mm) Wide									
EPJ-45	21" x 36" (533 x 914 mm)	21" (533 m m)	33.5" (851 m m)	56" (1422 m m)	50.1" (1273 m m)	61.9" (1572 m m)	7.6" (193 m m)	875	397
	21" x 48" (533 x 1219 mm)		45.5" (1156 m m)	68" (1727 m m)	59.1" (1501 m m)	70.9" (1800 m m)		880	399
Fork Dimension: 18" (457mm) Wide									
EPJ-45	18" x 36" (457 x 914 mm)	18" (457 m m)	33.5" (851 m m)	56" (1422 m m)	50.1" (1273 m m)	61.9" (1572 m m)	4.6" (117 m m)	875	397
	18" x 48" (457 x 1219 mm)		45.5" (1156 m m)	68" (1727 m m)	64.9" (1648 m m)	70.9" (1800 m m)		880	399

Dimensions listed above are based on 9.1" battery compartment

* Estimated shipping weight with (2) battery



LONDON, Ontario
331 Sovereign Road
London, ON N6M 1A6
Phone: 519-452-7770
Email: info@liftdepot.com

WINDSOR, Ontario
2-5900 Rhodes Drive
Windsor, ON N8N 2M1
Phone: 519-988-0006
Email: info@liftdepot.com

STRATFORD, Ontario
557 Lorne Ave. East
Stratford, ON N5A 6S4
Phone: 519-273-7664
Email: info@liftdepot.com

CAMBRIDGE, Ontario
45 Barnes Road
Cambridge, ON N3H 4R7
Phone: 519-653-4713
Email: info@liftdepot.com

WWW.LIFTDEPOT.COM